

A B C D E F G H

UNIT MM

PART NO. = FAS-00162

REVISIONS			
LTR	DESCRIPTION	DATE	APP.

1
2
3
4
5

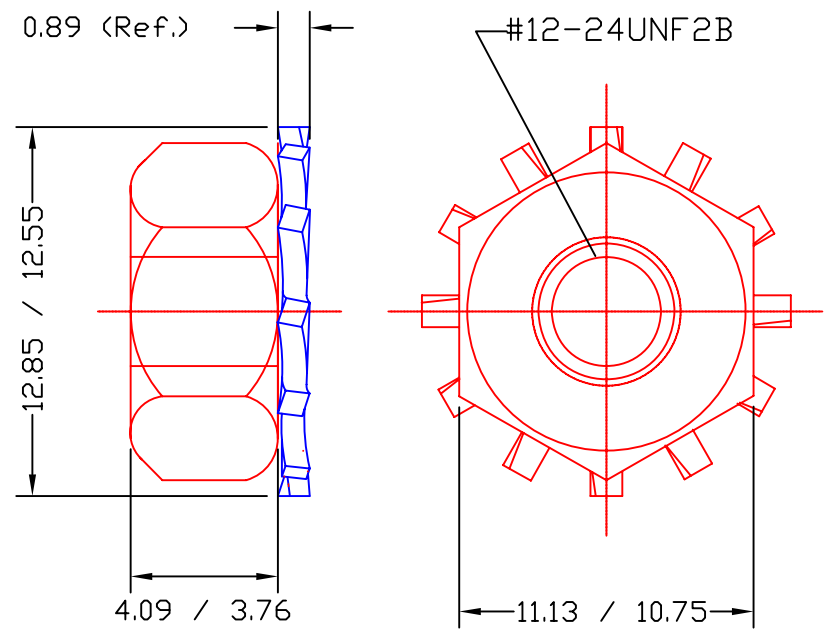

NOTE :

- a) Spec. : #12-24 KEPS-NU-STL-Z Floating-Nut-1224, Captive-Fastener
- b) EXTERNAL TEETH LOCK WASHER : SAE 1050 Carbon Steel (Sprong Steel By HRC45 (Ave.)) + Hardened + Zinc Plated CR3+ In Surface.
- c) Nut : SAE 1008CHQ Carbon Steel + Zinc Plated CR3+ In Surface.
- d) Installation Force = 50 kgf (Ave.)
- e) Clamping Force = 15 kgf (Ave.)
- f) Sheet Hardness = HRB 70 (Max.), (Panel For Cold-Rolled-Steel Used)
- g) Being Accompanied By European RoHS Latest Standard In 2010.

Tengscrew Co., Ltd.					CLIENT CONFIRMED	
					SIGNED	
NAME Floating-Nut-1224, Captive-Fastener					DATE	
					APPROVED Johnson	
TOL. ±	1 PLC	2 PLC	ANGLE	UNIT	mm	DESIGNED Tommy
MATERIAL	SEE NOTE			SCALE	4:1	DRAWN Tommy
FINISH	SEE NOTE			DATE	25-Aug.-10	REV. 0A
THE 3RD PROJECTION				DWG. NO.	FAS-00162	1/1

PROPRIETARY NOTE: THIS SHEET OF ENGINEERING DRAWINGS AND SPECIFICATIONS CONTAINS CONFIDENTIAL, TRADE SECRET, AND OTHER PROPRIETARY INFORMATION OF TENGSCREW CO., LTD. THIS DOCUMENT MAY NOT BE TRANSFERRED OR COPIED WITHOUT THE EXPRESS WRITTEN AUTHORIZATION OF TENGSCREW. IN ADDITIONAL, NEITHER THIS SHEET NOR THE INFORMATION IT CONTAINS MAY BE USED BY OR DISCLOSED TO ANY THIRD PARTY WITHOUT TENGSCREW'S EXPRESS WRITTEN CONSENT.

A B C D E F G H

A		B		C		D		E		F		G		H					
UNIT		MM		PART NO. = FAS-00164								REVISIONS							
												LTR		DESCRIPTION		DATE		APP.	

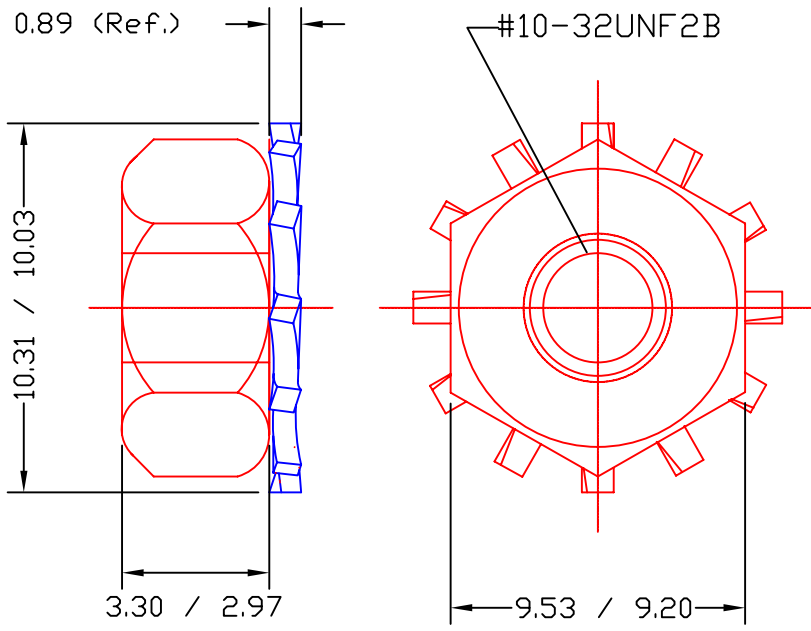

- NOTE :
- a) Spec. : #10-32 KEPS-NU-STL-Z Floating-Nut-1032, Captive-Fastener
 - b) EXTERNAL TEETH LOCK WASHER : SAE 1050 Carbon Steel (Sprong Steel By HRC45 (Ave.)) + Hardened + Zinc Plated CR3+ In Surface.
 - c) Nut : SAE 1008CHQ Carbon Steel + Zinc Plated CR3+ In Surface.
 - d) Installation Force = 50 kgf (Ave.)
 - e) Clamping Force = 15 kgf (Ave.)
 - f) Sheet Hardness = HRB 70 (Max.). (Panel For Cold-Rolled-Steel Used)
 - g) Being Accompanied By European RoHS Latest Standard In 2010.

PROPRIETARY NOTE: THIS SHEET OF ENGINEERING DRAWINGS AND SPECIFICATIONS OF TENGSCREW CO., LTD. THIS DOCUMENT MAY NOT BE TRANSFERRED OR COPIED WITHOUT THE EXPRESS WRITTEN AUTHORIZATION OF TENGSCREW. CONTAINS CONFIDENTIAL, TRADE SECRET, AND OTHER PROPRIETARY INFORMATION. IN ADDITIONAL, NEITHER THIS SHEET NOR THE INFORMATION IT CONTAINS MAY BE USED BY OR DISCLOSED TO ANY THIRD PARTY WITHOUT TENGSCREW'S EXPRESS WRITTEN CONSENT.

Tengscrew Co., Ltd.						CLIENT CONFIRMED	
						SIGNED	
						DATE	
NAME	Floating-Nut-1032, Captive-Fastener			APPROVED		Johnson	
TOL. ±	1 PLC	2 PLC	ANGLE	UNIT	mm	DESIGNED Tommy	
MATERIAL	SEE NOTE			SCALE	4:1	DRAWN Tommy	
FINISH	SEE NOTE			DATE	25-Aug-10	REV.	0A
THE 3RD PROJECTION				DWG. NO.	FAS-00164	1/1	