

Drawing & Part No. LB3-20-01-REV.A 4MM L型板手	Description SCM435-HEX KEYS-A/F4.00-L2.20.00xL1.60.00	Rev. 0
--	--	-----------

Taipei Date : JUNE/03/2013

UNIT : MM

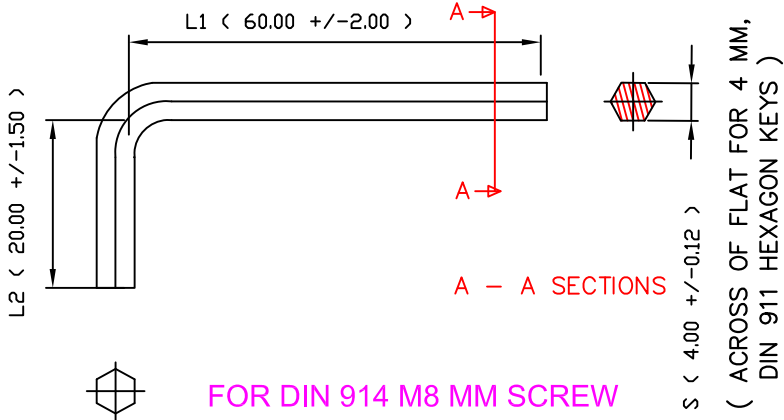

NOT TO SCALE

Materials	Specifications		Remarks	
SCM 435 ALLOY-STEEL	S	4.00 +/- 0.12		
Hardness 60 HRC - 50 HRC	L1	60.00 +/- 2.00		
Breaking Torque 163 kgf.cm Mini.-Valued	L2	20.00 +/- 1.50		
Finish NICKEL PLATED 表面鍍鎳處理	A	X		
	B	X		
Salt Spray Test 12 HOURS	C	X		
	D	X		
Customer MIL	E	X		
	F	X		
Confirmed By	G	X		
	Driver 4MM HEXAGON KEYS		H	X
Part No. LB3-20-01-REV.A 4MM L型板手				

TENGSCREW CO., LTD.
鄧記有限公司

DRAWN

Tommy
05.31.2013

CHECKED

Tommy
05.31.2013

APPROVED

Johnson
06.03.2013

Drawing & Part No. LB3-20-01-REV.A 5MM L型板手	Description SCM435-HEX KEYS-A/F5.00-L2.22.00xL1.70.00	Rev. 1
--	--	-----------

Taipei Date : JUNE/03/2013

UNIT : MM

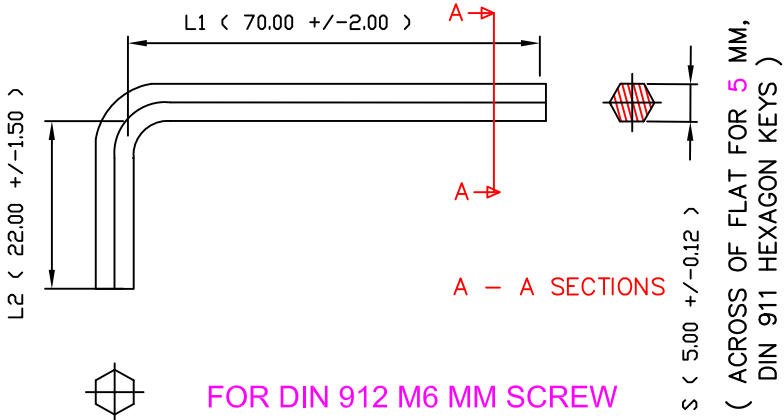

NOT TO SCALE

Materials	Specifications		Remarks	
SCM 435 ALLOY-STEEL	S	5.00 +/- 0.12		
Hardness 60 HRC - 50 HRC	L1	70.00 +/- 2.00		
Breaking Torque 306 kgf.cm Mini.-Valued	L2	22.00 +/- 1.50		
Finish NICKEL PLATED 表面鍍銀處理	A	X		
	B	X		
Salt Spray Test 12 HOURS	C	X		
	D	X		
Customer MIL	E	X		
	F	X		
Confirmed By	G	X		
	Driver	5MM HEXAGON KEYS	H	X
Part No. LB3-20-01-REV.A 5MM L型板手				

TENGSCREW CO., LTD.
鄧記有限公司

DRAWN

CHECKED

APPROVED

Tommy
05.31.2013

Tommy
05.31.2013

Johnson
06.03.2013

Drawing & Part No. TENGW000001 手動L型圓桿	Description T1-T10-Dia.3.00-W.17.00xL.51,00	Rev. 0
--	--	-----------

Taipei Date : AUG./05/2009

UNIT : mm

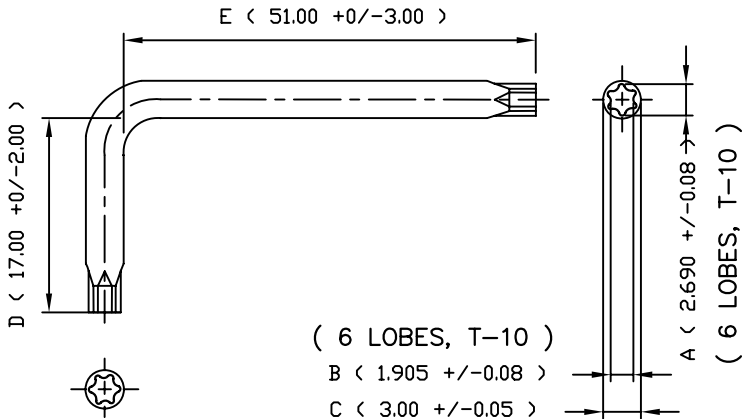

NOT TO SCALE

Materials	Specifications		Remarks	
6150 Alloy (CrV Alloy)	A	2.690 +/- 0.08		
Hardness 60 HRC - 50 HRC	B	1.905 +/- 0.08		
Breaking Torque 22.50 kgf.cm Max.-Valued	C	3.00 +/- 0.05		
Finish BLACK OXIDED TREATMENT 表面染黑處理	D	17.00 +0/-2.00		
	E	51.00 +0/-3.00		
Salt Spray Test 12 Hours	F	X		
	G	X		
Customer	H	X		
	J	X		
Confirmed By	K	X		
	Driver 6 Lobes T-10, DOUBLE-WAY		I	X

TENGSCREW CO., LTD.
鄧記有限公司

DRAWN

Tommy
08.04.2009

CHECKED

Tommy
08.05.2009

APPROVED

Johnson
08.06.2009