

8 7 6 5 4 3 2 1

PART REV.	DWG. REV.	ECO#	ZONE	DESCRIPTION OF CHANGE	REV. BY	APPD	DATE
A	A			CREATE FOR NEW DRAWING	ERIC		07-08-'10

NOTE:  
 1.MATERIAL: SAE 1215MS STEEL 鐵材  
 2.FINISH: 鍍亮鉻  
 3.SPEC.: 8.00 x 96 x 32 -  
 #8-32 x 9 + MM  
 4. DES.: ROUND TYPE  
 HANDLES

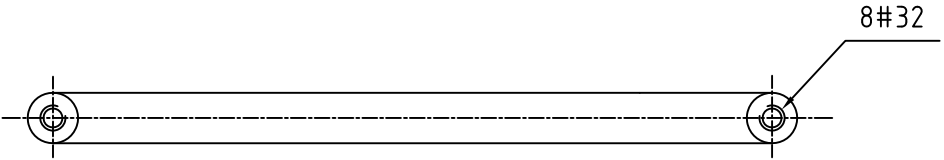
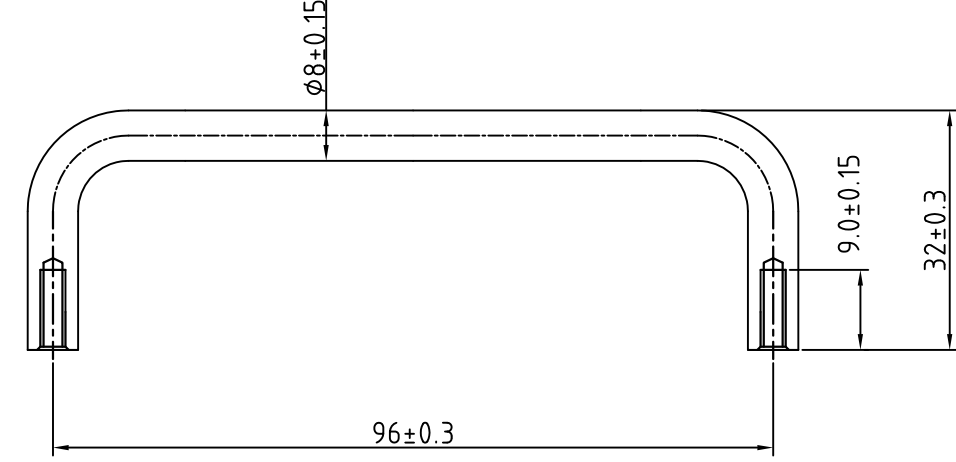

F  
E  
D  
C  
B  
A

F  
E  
D  
C  
B  
A

©copyright 1995 majestic technology corporation.

TOLERANCES (EXCEPT TITLE BLOCK DATA AND UNLESS OTHERWISE SPECIFIED)	DATE 07-08-'10	TENSCREW CO., LTD.
LINEAR ANGLES	CHECKED BY DATE	
ALL DIMENSION ARE IN: MM	APPROVED BY DATE	PART NAME:
THIRD ANGLE PROJECTION	DWG. NO. 68-5042	HANDLE,3U/5U,BN
SIZE A	PART NO. 68-5042-01	REV. x
		SCALE : 1 : 1
		SHEET 1 OF 1

8 7 6 5 4 3 2 1 Pro-ENGINEER

Drawing & Part No. TENGC000029 手動圓形把手	Description ∅5.00-∅30.00-H25.00-M3xP.0.5牙xT6	Rev. 2
------------------------------------------	-------------------------------------------------	-----------

Taipei Date : MAR./10/2014

螺絲牙以標準環規 M3xP.0.5 MM 牙為標準 x 2

UNIT : MM

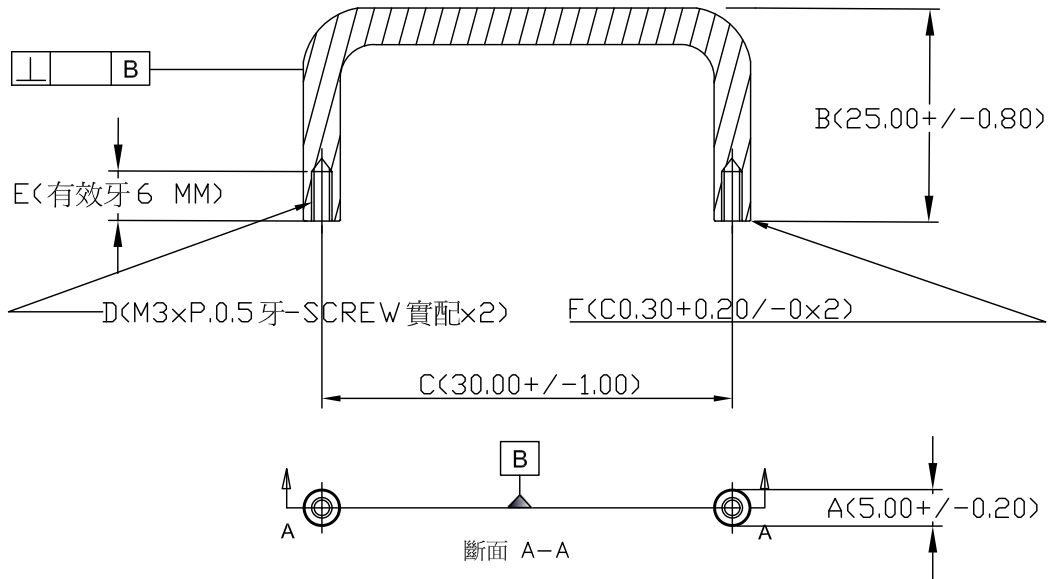

NOT TO SCALE

Materials	Specifications		Remarks
SAE 1215MS CUTTING STEEL 快削鋼材質 ( 編號 1215 )	A	5.00 + / - 0.20	
Hardness	B	25.00 + / - 0.80	
95 HRB - 80 HRB (無熱處理)	C	30.00 + / - 1.00	
Finish	D	M3xP.0.5MM 牙-SCREW 實配x2	
ELECTRO-DEPOSIT-COATING 表面黑色電著塗裝 (EDP)	E	有攻牙 6 MM (孔深 8 MM)	
Salt Spray Test	F	C0.30 + 0.20 / -0 (x2)	
12 HOURS	G	X	
Customer	H	X	
TMC	J	X	
Confirmed By	K	X	
Part No.			
Description	∅5.00-∅30.00-25.00-M3xP.0.5牙xT6		I X

TENGSCREW CO., LTD.  
鄧 記 有 限 公 司

DRAWN

CHECKED

APPROVED

Tommy  
03.10.2014

Tommy  
03.10.2014

Johnson  
03.10.2014

Drawing & Part No. TENGC000028 手動圓形把手	Description ∅8.00-∅100.00-H38.00-M5xP.0.8牙xT11	Rev. 1
------------------------------------------	---------------------------------------------------	-----------

Taipei Date : FEB./24/2014

螺絲牙以標準環規 M5xP.0.8 MM 牙為標準 x 2

UNIT : MM

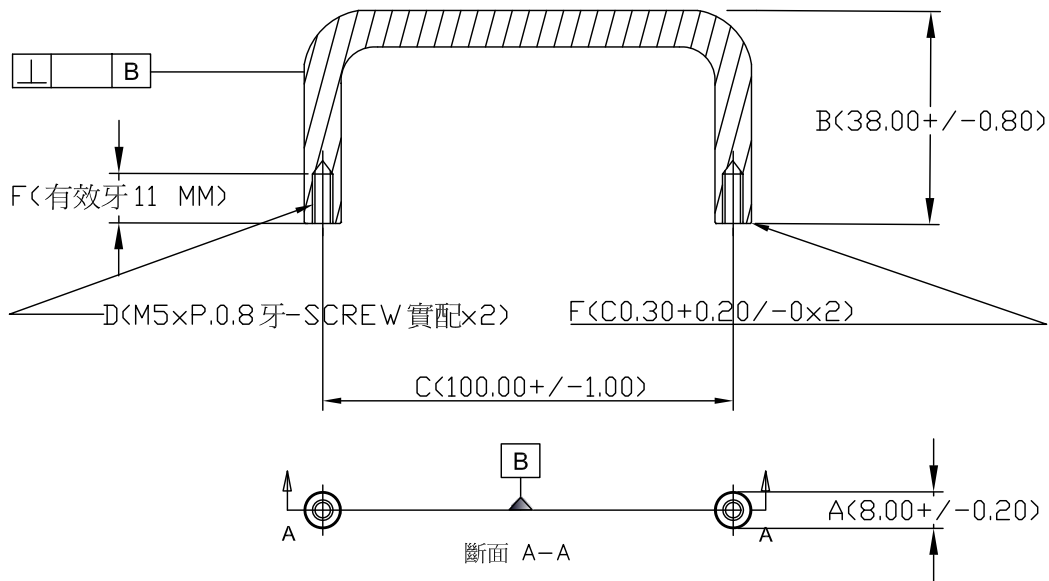

NOT TO SCALE

Materials	Specifications		Remarks
SAE 1215MS CUTTING STEEL 快削鋼材質 ( 編號 1215 )	A	8.00 +/- 0.20	
Hardness	B	38.00 +/- 0.80	
95 HRB - 80 HRB (無熱處理)	C	100.00 +/- 1.00	
Finish	D	M5xP.0.8MM 牙- SCREW 實配x2	
NICKEL PLATED TREATMENT 表面環保鍍鎳處理	E	有攻牙 11 MM ( 孔深 13 MM )	
Salt Spray Test	F	C0.30 +0.20 / -0 ( x2 )	
12 HOURS	G	X	
Customer	H	X	
XYZ	J	X	
Confirmed By	K	X	
Part No.			
Description	∅8.00-∅100.00-H38.00-M5xP.0.8牙xT11		I X

TENGSCREW CO., LTD.  
鄧 記 有 限 公 司

DRAWN

CHECKED

APPROVED

Tommy  
02.24.2014

Tommy  
02.24.2014

Johnson  
02.24.2014

Drawing & Part No. TENGC000027 手動圓形把手	Description ∅8.00-∅60.00-H36.00-M5xP.0.8牙xT11	Rev. 0
------------------------------------------	--------------------------------------------------	-----------

Taipei Date : FEB./07/2014

螺絲牙以標準環規 M5xP.0.8 MM 牙為標準 x 2

UNIT : MM

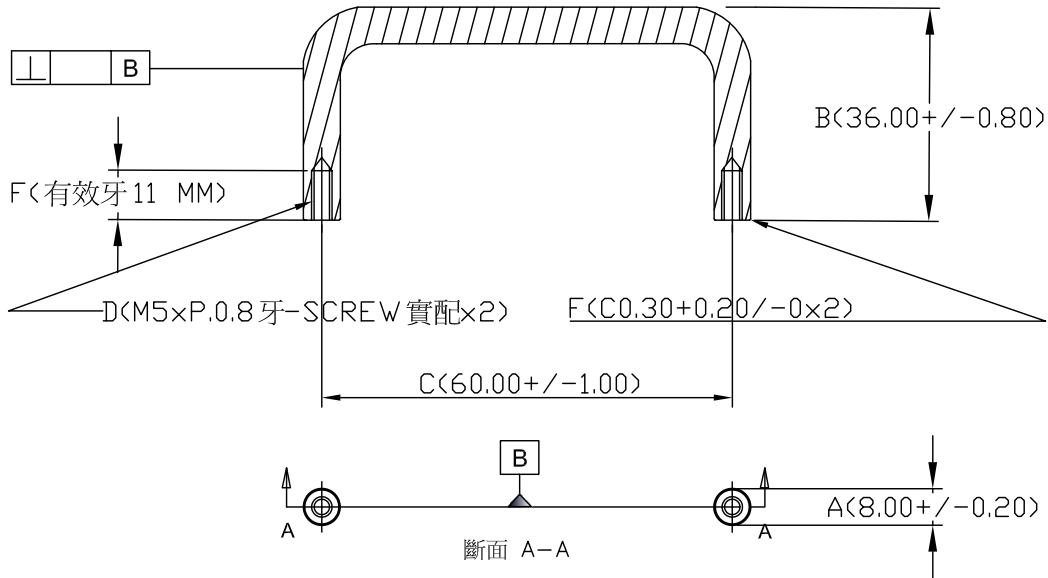

NOT TO SCALE

Materials	Specifications		Remarks	
SAE 1215MS CUTTING STEEL 快削鋼材質 (編號 1215)	A	8.00 +/- 0.20		
Hardness	B	36.00 +/- 0.80		
95 HRB - 80 HRB (無熱處理)	C	60.00 +/- 1.00		
Finish	D	M5xP.0.8MM牙-SCREW實配x2		
CHROMIUM PLATED TREATMENT 表面環保鍍亮鉻處理	E	有攻牙 11 MM (孔深 13 MM)		
Salt Spray Test	F	C0.30 +0.20 / -0 (x2)		
12 HOURS	G	X		
Customer	H	X		
RPT	J	X		
Confirmed By	K	X		
Part No.			I	X
Description	∅8.00-∅60.00-H36.00-M5xP.0.8牙xT11			

TENGSCREW CO., LTD.  
鄧記有限公司

DRAWN

CHECKED

APPROVED

Tommy  
02.07.2014

Tommy  
02.07.2014

Johnson  
02.08.2014

Drawing & Part No. TENGC000026 手動圓形把手	Description ∅8.00-∮104.00-H34.00-M4xP.0.7牙xT11	Rev. 1
------------------------------------------	---------------------------------------------------	-----------

Taipei Date : FEB./07/2014

螺絲牙以標準環規 M4xP.0.7 MM 牙為標準 x 2

UNIT : MM

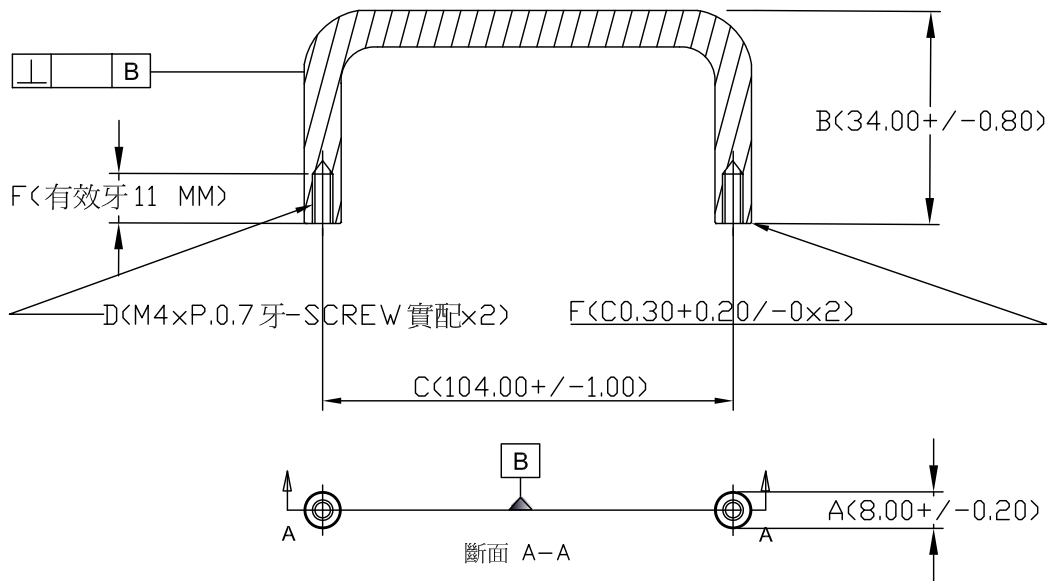

NOT TO SCALE

Materials	Specifications		Remarks	
SAE 1215MS CUTTING STEEL 快削鋼材質 ( 編號 1215 )	A	8.00 +/- 0.20		
Hardness	B	34.00 +/- 0.80		
95 HRB - 80 HRB (無熱處理)	C	104.00 +/- 1.00		
Finish	D	M4xP.0.7MM 牙- SCREW 實配x2		
CHROMIUM PLATED TREATMENT 表面環保鍍亮鉻處理	E	有攻牙 11 MM ( 孔深 13 MM )		
Salt Spray Test	F	C0.30 +0.20 / -0 ( x2 )		
12 HOURS	G	X		
Customer	H	X		
RPT	J	X		
Confirmed By	K	X		
Part No.			I	X
Description	∅8.00-∮104.00-H34.00-M4xP.0.7牙xT11			

TENGSCREW CO., LTD.  
鄧 記 有 限 公 司

DRAWN

CHECKED

APPROVED

Tommy  
02.07.2014

Tommy  
02.07.2014

Johnson  
02.08.2014

<b>Drawing &amp; Part No.</b> TENGCO00025手動圓形把手	<b>Description</b> $\varnothing 5.00 - \varnothing 33.00 - H19.00 - M3 \times P.0.5$ 牙 $\times T5$	<b>Rev.</b> 0
----------------------------------------------------	-------------------------------------------------------------------------------------------------------	------------------

Taipei Date : OCT./07/2013

螺絲牙以標準環規 M3xP.0.5 MM 牙為標準 x 2

UNIT : MM

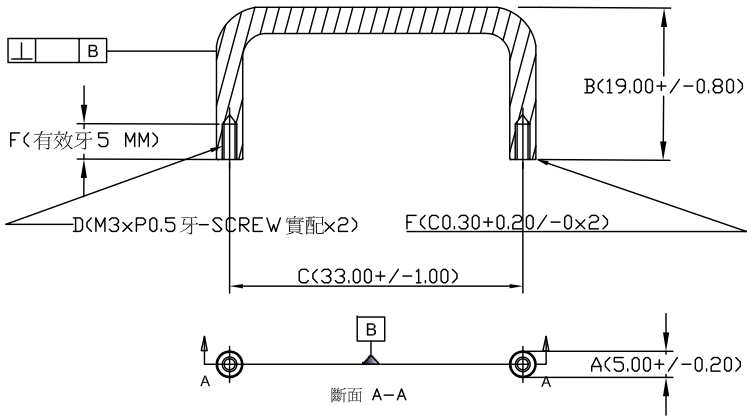

NOT TO SCALE

Materials	Specifications		Remarks	
SAE 1215MS CUTTING STEEL 鐵材質 ( 編號 1215 )	A	5.00 +/- 0.20		
Hardness	B	19.00 +/- 0.80		
95 HRB - 80 HRB ( 無熱處理 )	C	33.00 +/- 1.00		
Finish	D	M3xP0.5牙-SCREW實配x2		
NICKEL-PLATED-TREATMENT 表面環保鍍鎳處理	E	有攻牙 5 MM ( 孔深 7 MM )		
Salt Spray Test	F	C0.30 +0.20 / -0 ( x2 )		
12 HOURS	G	X		
Customer	H	X		
RIN	J	X		
Confirmed By	K	X		
Part No.				
Description	$\varnothing 5.00 - \varnothing 33.00 - H19.00 - M3 \times P.0.5$ 牙 $\times T5$			

**TENGSCREW CO., LTD.**  
 鄧 記 有 限 公 司

DRAWN

CHECKED

APPROVED

Tommy  
10.07.2013

Tommy  
10.07.2013

Johnson  
10.07.2013

Drawing & Part No. TENGC000020 手動圓形把手	Description ø8.00-ø76.00-H27.00-#8-32牙xT7	Rev. 1
------------------------------------------	----------------------------------------------	-----------

Taipei Date : JULY/30/2013

螺絲牙以標準環規 #8-32 牙為標準 x 2

UNIT : MM

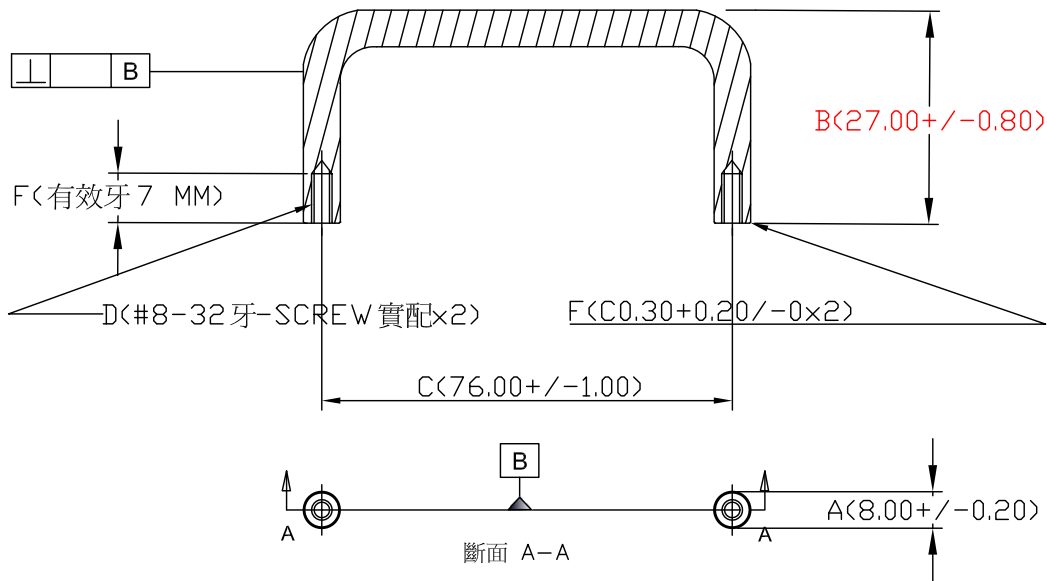

NOT TO SCALE

Materials	Specifications		Remarks	
AISI 304 STAINLESS STEEL 不銹鋼材質 ( 編號 304 )	A	8.00 +/- 0.20		
Hardness	B	27.00 +/- 0.80		
17 HRC - 21 HRC	C	76.00 +/- 1.00		
Finish	D	#8-32 牙-SCREW 實配x2		
CLEANING & RESISTANCE RUST 表面清淨 & 防銹處理	E	有攻牙 7 MM ( 孔深 9 MM )		
Salt Spray Test	F	C0.30 +0.20 / -0 ( x2 )		
24 HOURS	G	X		
Customer	H	X		
COM	J	X		
Confirmed By	K	X		
Part No.	ø8.00-ø76.00-H27.00-#8-32牙xT7		I	X
Description				

TENGSCREW CO., LTD.  
鄧 記 有 限 公 司

DRAWN

CHECKED

APPROVED

Tommy  
07.29.2013

Tommy  
07.29.2013

Johnson  
07.30.2013

<b>Drawing &amp; Part No.</b> TENGCO00019 手動圓形把手	<b>Description</b> $\varnothing 8.00 - \varnothing 64.00 - H27.00 - \#8 - 32 \text{ 牙} \times T7$	<b>Rev.</b> 1
-----------------------------------------------------	------------------------------------------------------------------------------------------------------	------------------

Taipei Date : JULY/26/2013

螺絲牙以標準環規 #8-32 牙為標準 x 2

UNIT : MM

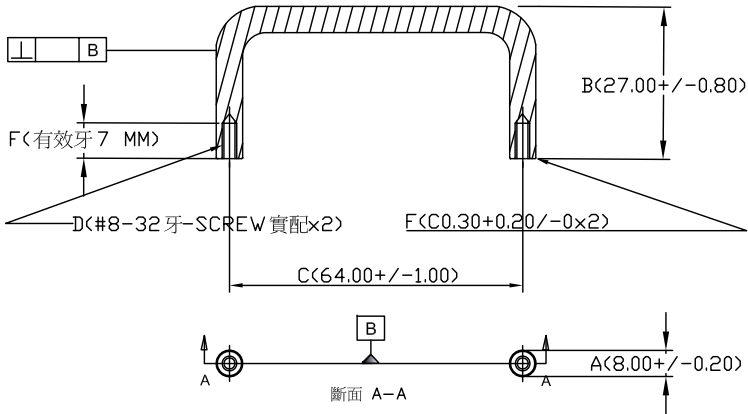

NOT TO SCALE

Materials		Specifications		Remarks
<b>AISI 303 STAINLESS STEEL</b> 不銹鋼材質 (編號 303)		A	8.00 +/- 0.20	
<b>Hardness</b> 17 HRC - 21 HRC		B	27.00 +/- 0.80	
<b>Finish</b> CLEANING & RESISTANCE RUST 表面清淨 & 防銹處理		C	64.00 +/- 1.00	
<b>Salt Spray Test</b> 24 HOURS		D	#8-32 牙-SCREW 實配 x2	
<b>Customer</b> COM		E	有攻牙 7 MM (孔深 9 MM)	
<b>Confirmed By</b>		F	C0.30 +0.20 / -0 ( x2 )	
<b>Part No.</b>		G	X	
<b>Description</b>		H	X	
		J	X	
		K	X	
		$\varnothing 8.00 - \varnothing 64.00 - H27.00 - \#8 - 32 \text{ 牙} \times T7$		I X

**TENGSCREW CO., LTD.**  
 鄧 記 有 限 公 司

DRAWN

CHECKED

APPROVED

Tommy  
07.26.2013

Tommy  
07.26.2013

Johnson  
07.26.2013



<b>Drawing &amp; Part No.</b> TENG000017 手動圓形把手	<b>Description</b> $\varnothing 10.00 - \varnothing 100.00 - H50.00 - M4 \times P.0.70 \times T11$	<b>Rev.</b> 1
----------------------------------------------------	-------------------------------------------------------------------------------------------------------	------------------

Taipei Date : JUNE/18/2013

螺絲牙以標準環規 M4xP.0.70 MM 牙為標準 x2

UNIT : MM

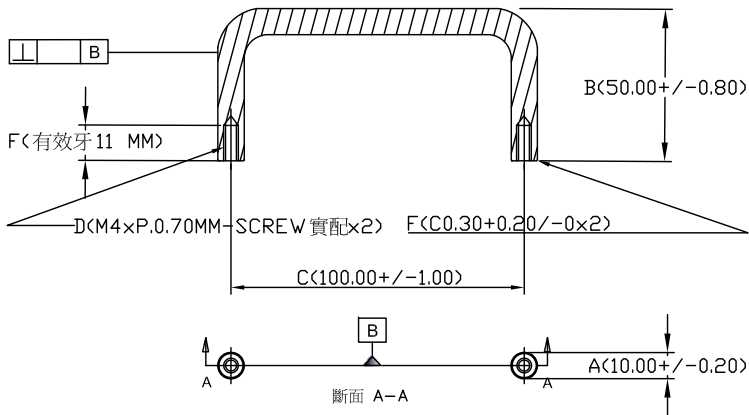

NOT TO SCALE

Materials	Specifications		Remarks	
AISI 304 STAINLESS STEEL 不銹鋼材質 ( 編號 304 )	A	10.00 +/- 0.20		
Hardness	B	50.00 +/- 0.80		
17 HRC - 21 HRC	C	100.00 +/- 1.00		
Finish	D	M4xP.0.7MM 牙- SCREW實配x2		
VIBRATION GROUND 表面振動亮面處理	E	有攻牙 11 MM ( 孔深 13 MM )		
Salt Spray Test	F	C0.30 + 0.20 / - 0 ( x2 )		
24 HOURS	G	X		
Customer	H	X		
WE	J	X		
Confirmed By	K	X		
Part No.	$\varnothing 10.00 - \varnothing 100.00 - H50.00 - M4 \times P.0.70 \times T11$		I	X
Description				

**TENGSCREW CO., LTD.**  
 鄧 記 有 限 公 司

DRAWN

CHECKED

APPROVED

Tommy  
06.18.2013

Tommy  
06.18.2013

Johnson  
06.18.2013

<b>Drawing &amp; Part No.</b> TENGCO00019 手動圓形把手	<b>Description</b> $\varnothing 8.00 - \text{C}64.00 - \text{H}27.00 - \#8 - 32 \text{ 牙} \times \text{T}7$	<b>Rev.</b> 1
-----------------------------------------------------	----------------------------------------------------------------------------------------------------------------	------------------

Taipei Date : JULY/26/2013

螺絲牙以標準環規 #8-32 牙為標準 x 2

UNIT : MM

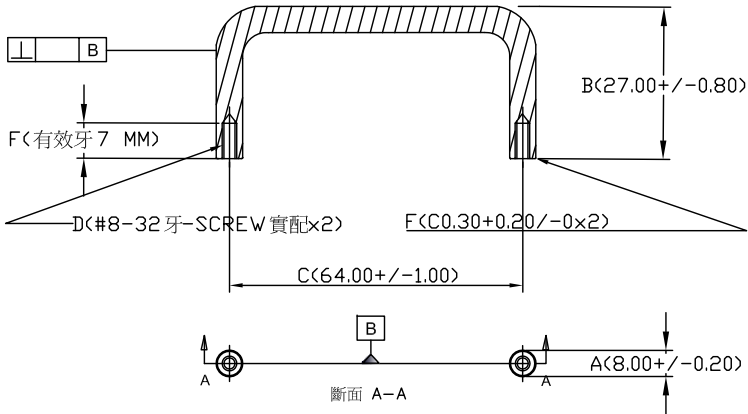

NOT TO SCALE

Materials		Specifications		Remarks
<b>AISI 303 STAINLESS STEEL</b> 不銹鋼材質 (編號 303)		A	8.00 +/- 0.20	
<b>Hardness</b> 17 HRC - 21 HRC		B	27.00 +/- 0.80	
<b>Finish</b> CLEANING & RESISTANCE RUST 表面清淨 & 防銹處理		C	64.00 +/- 1.00	
<b>Salt Spray Test</b> 24 HOURS		D	#8-32 牙-SCREW 實配 x 2	
<b>Customer</b> COM		E	有攻牙 7 MM (孔深 9 MM)	
<b>Confirmed By</b>		F	C0.30 + 0.20 / - 0 ( x 2 )	
<b>Part No.</b>		G	X	
<b>Description</b>		H	X	
		J	X	
		K	X	
		$\varnothing 8.00 - \text{C}64.00 - \text{H}27.00 - \#8 - 32 \text{ 牙} \times \text{T}7$		I X

**TENGSCREW CO., LTD.**  
 鄧記有限公司

DRAWN

CHECKED

APPROVED

Tommy  
07.26.2013

Tommy  
07.26.2013

Johnson  
07.26.2013

Drawing & Part No. TENGC000009 手動圓形把手	Description ø8.00-ø76.20-H40.00-M4xP.0.70xT11	Rev. 1
------------------------------------------	--------------------------------------------------	-----------

Taipei Date : APR./23/2013

螺絲牙以標準環規 M4xP.0.70 MM 牙為標準 x2

UNIT : MM

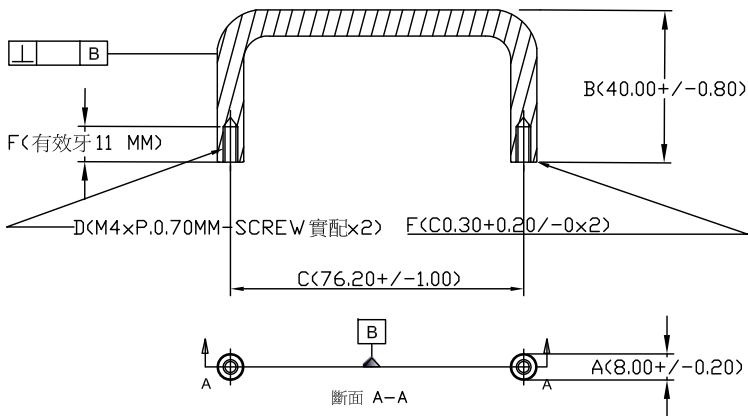

NOT TO SCALE

Materials AISI 6063 ALUMINUM ALLOY 鋁合金材質 ( 編號 6063 )	Specifications		Remarks
Hardness 83 HV ( REF. VALUED )	A	8.00 +/- 0.20	
Finish NATURAL ANODIZING 表面原色陽極處理	B	40.00 +/- 0.80	
Salt Spray Test 12 HOURS	C	76.20 +/- 1.00	
Customer AT	D	M4xP.0.70MM 牙-SCREW 實配x2	
Confirmed By	E	有攻牙 11 MM ( 孔深 13 MM )	
Part No.	F	C0.30 +0.20 / -0 ( x2 )	
Description	G	X	
	H	X	
	J	X	
	K	X	
	ø8.00-ø76.20-H40.00-M4xP.0.70xT11		I X

TENGSCREW CO., LTD.  
鄧 記 有 限 公 司

DRAWN

CHECKED

APPROVED

Tommy  
12.16.2013

Tommy  
12.16.2013

Johnson  
12.16.2013

<b>Drawing &amp; Part No.</b> TENGCO000009手動圓形把手	<b>Description</b> $\varnothing 9.50-\varnothing 76.20-H40.00-M4 \times P.0.70 \times T11$	<b>Rev.</b> 0
-----------------------------------------------------	-----------------------------------------------------------------------------------------------	------------------

Taipei Date : APR./23/2013

螺絲牙以標準環規 M4xP.0.70 MM 牙為標準 x2

UNIT : MM

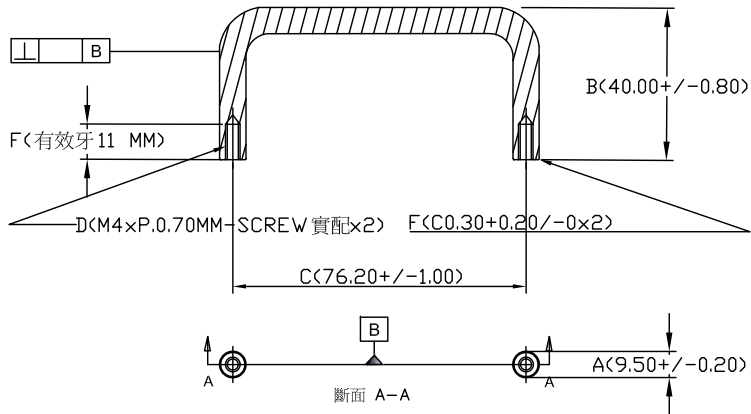

NOT TO SCALE

Materials	Specifications		Remarks	
AISI 6063 ALUMINUM ALLOY 鋁合金材質 ( 編號 6063 )	A	9.50 +/- 0.20		
Hardness 83 HV ( REF. VALUED )	B	40.00 +/- 0.80		
Finish NATURAL ANODIZING 表面原色陽極處理	C	76.20 +/- 1.00		
	D	M4xP.0.7MM 牙- SCREW 實配x2		
Salt Spray Test 12 HOURS	E	有攻牙 11 MM ( 孔深 13 MM )		
Customer	F	C0.30 +0.20 / -0 ( x2 )		
	G	X		
Confirmed By	H	X		
	J	X		
Part No.	K	X		
	Description			
		$\varnothing 9.50-\varnothing 76.20-H40.00-M4 \times P.0.70 \times T11$	I	X

**TENGSCREW CO., LTD.**  
 鄧 記 有 限 公 司

DRAWN

CHECKED

APPROVED

Tommy  
04.22.2013

Tommy  
04.22.2013

Johnson  
04.23.2013

Drawing & Part No. TENGL000001 手動U型把手	Description $\bar{\phi}6 - \bar{C}28.00 - H22.80 - \#6 - 32 \times D8$	Rev. 1
------------------------------------------	---------------------------------------------------------------------------	-----------

Taipei Date : NOV./22/2011

UNIT : MM

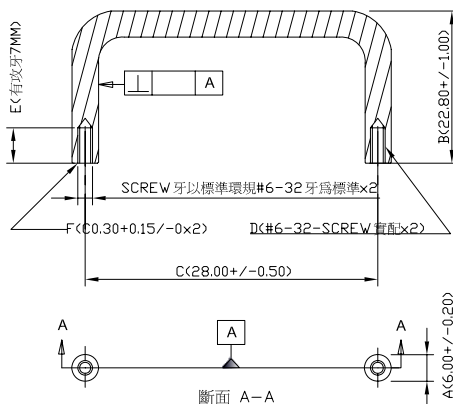

NOT TO SCALE

Materials	Specifications		Remarks	
SAE1215MS FREE CUTTING STEEL	A	6.00 +/- 0.20		
Hardness	B	22.80 +/- 1.00		
95 HRB - 80 HRB (無熱處理)	C	28.00 +/- 0.50		
Finish	D	#6-32牙-SCREW實配x2		
NICKEL PLATED TREATMENT 表面環保鍍鎳處理	E	有攻牙7MM (孔深9MM)		
Salt Spray Test	F	C0.30+0.15/-0 (x2)		
12 HOURS	G	X		
Customer	H	X		
連翊科技有限公司	J	X		
Confirmed By	K	X		
Part No.	$\bar{\phi}6 - \bar{C}28.00 - H22.80 - \#6 - 32 \times D8$		I	X
Description				

TENGSCREW CO., LTD.  
鄧記有限公司

DRAWN

CHECKED

APPROVED

Tommy  
11.22.2011

Tommy  
11.22.2011

Johnson  
11.23.2011

Drawing & Part No. TENGW000005手動口型把手	Description ø5-φ37-H22-M3xP0.5xD6	Rev. 0
-----------------------------------------	--------------------------------------	-----------

Taipei Date : DEC./23/2010

UNIT : MM

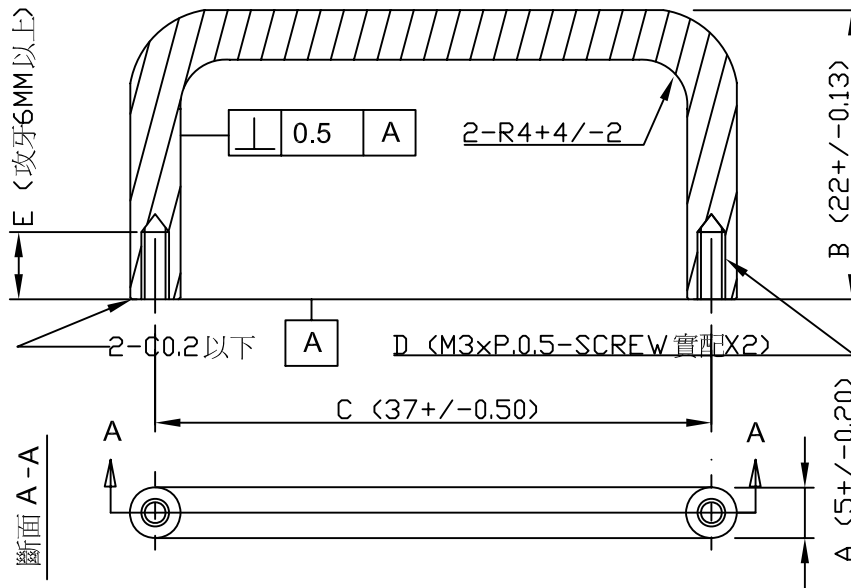

NOT TO SCALE

Materials	Specifications		Remarks	
SUS 303 STAINLESS STEEL	A	5 +/- 0.20	a) Remove burres and break all sharp edges. b) Part must have no dirt and rust. c) Specifications : E of 攻牙6.00MM以上, be equal to your actual tolerances by using.	
Hardness 21 HRC - 16 HRC	B	22 +/- 0.13		
Finish VIBRATION FINISHING TREATMENT 表面振動拋光處理	C	37 +/- 0.50		
Salt Spray Test 12 Hours	D	M3xP.0.5-SCREW實配x2		
	E	攻牙6.00MM以上		
Customer	F	X		
Confirmed By	G	X		
Part No. 50-002611-XX	H	X		
	J	X		
	K	X		
Description Handle PCB FOR IM-700	ø5-φ37-H22-M3xP0.5xD6		I	X

TENGSCREW CO., LTD.  
鄧記有限公司

DRAWN

CHECKED

APPROVED

Tommy  
12.22.2010

Tommy  
12.22.2010

Johnson  
12.23.2010

Drawing & Part No. TENGW000003手動U型把手	Description $\bar{\phi}8-\bar{C}76.2-H31.5-M4xP0.7xD8$	Rev. 1
-----------------------------------------	-----------------------------------------------------------	-----------

Taipei Date : NOV./18/2010

UNIT : MM

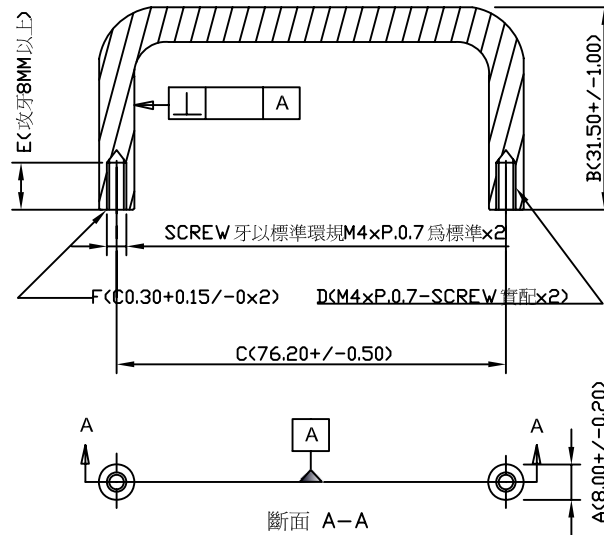

NOT TO SCALE

Materials	Specifications		Remarks	
SAE1215MS FREE CUTTING STEEL	A	8.00 +/- 0.20		
Hardness	B	31.50 +/- 1.00		
95 HRB - 80 HRB (無熱處理)	C	76.20 +/- 0.50		
Finish	D	M4xP.0.7-SCREW實配x2		
NICKEL PLATED TREATMENT 表面環保鍍鎳處理	E	攻牙8.00MM以上		
Salt Spray Test	F	C0.30+0.15/-0 (x2)		
24 HOURS	G	X		
Customer	H	X		
Confirmed By	J	X		
Part No.	K	X		
34.5M305.001			I	X
Description	$\bar{\phi}8-\bar{C}76.2-H31.5-M4xP0.7xD8$			
HANDLE FRONT HU403				

TENGSCREW CO., LTD.  
鄧記有限公司

DRAWN

CHECKED

APPROVED

Tommy  
11.18.2010

Tommy  
11.18.2010

Johnson  
11.18.2010