

請用較粗的十字 No.2 起子頭

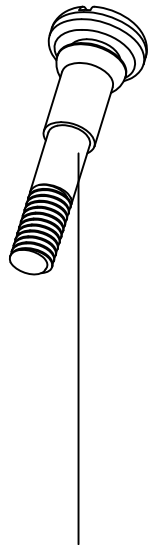

螺絲 (熱處理 + 鍍黑鋅)  
(1215MS 環保快削鋼)

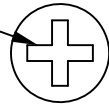
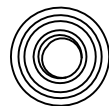
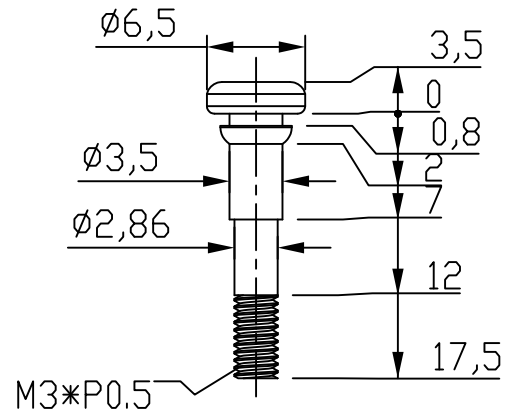

從上而下水平及適當受力壓縮



彈簧 (原色)  
(304 不銹鋼)

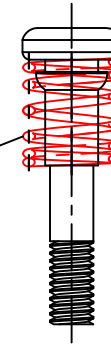

從上而下壓縮 2 mm 之承受力  
量為平均值 1.73 kgs +/- 0.35 kgs

實際摹擬彈簧裝入螺絲內測試

TENSCREW CO., LTD.	Model:	DRAWN BY	DESIGNED BY	MATERIAL	SCALE	UNIT	DRAWING NO.	REVISION	SHIFT NO.
	Item: KP-PDP-650-CPU-SCREWS	CHECKED BY	APPROVAL BY	DATE	2,00	mm			
				Dec-26-13					

Code SHR20030723	Description SHR 2.5*10.8-HNI凸肩(6*0.8)	Rev. 1
---------------------	--	-----------

UNIT:mm

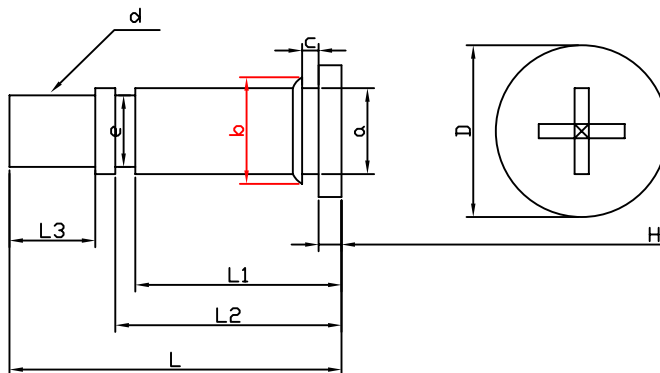

NOT TO SCALE

Material	Spec.		Remark	
C1018	D	6.00 +/-0.20	1) Assembly with SPR20030723 (SPR20030723-2) 2) Assembly with EOO20030723 3)92/07/23 變更b為3.60 +/-0.05 Teng 4)93/02/16 變更e為2.55 +0.06/-0 Teng	
Hardness Case Hardness : HV 450-550 Core Hardness : HV 280-380	H	0.80 +/-0.10		
Breaking Torque 9.30 kgf.cm Min.	L	11.60 +/-0.25		
Finish NICKEL	L1	7.20 +/-0.15		
	L2	7.90 +/-0.20		
Salt Spray Test N/A HR	L3	3.00 +/-0.15		
	a	3.00 +/-0.05		
Customer 808	b	3.60 +/-0.05		
	c	0.80 +/-0.10		
Part No. SHR20030723-1	e	2.55 +0.06/-0		
	Recess #1		d 2.38~2.48(M2.5*0.45) 6h	
TENSCREW CO., LTD.		DRAWN	CHECKED	APPROVED
		Daphne	Johnson	Johnson

Code SPR20030723	Description SPR 0.7*4.2*8.3-HSUS	Rev. 1
---------------------	-------------------------------------	-----------

UNIT:mm

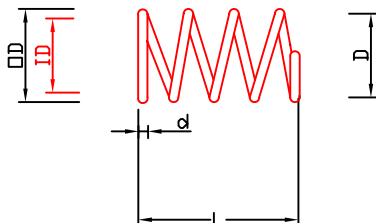

NOT TO SCALE

Material	Spec.		Remark
SUS 304	OD	4.90 +/-0.10	
Hardness	ID	3.50 +/-0.10	
N/A	D	4.20 ref.	
Breaking Torque	d	0.70 +/-0.05	
N/A	L	8.30 +/-0.30	
Finish	Left Turn 左旋		
Nickel	有效圈數(N) :3 總圈數(T) :5		
Salt Spray Test	彈力 當壓縮 2.50 mm 產生 2.30 kgs +/- 0.184kgs (K = 0.9146)		
N/A HR	其他 彈簧左右兩邊之內外徑尺寸必須一致		
Customer	注意 與 SHR20030723 & EOO20030723 實配		
808	Recess		
Part No.	N/A		

TENSCREW CO., LTD.	DRAWN	CHECKED	APPROVED
	Daphne	Johnson	Johnson

Code EOO20030723	Description EOO 2.5*6*0.4-HNI	Rev. 1
---------------------	----------------------------------	-----------

UNIT:mm

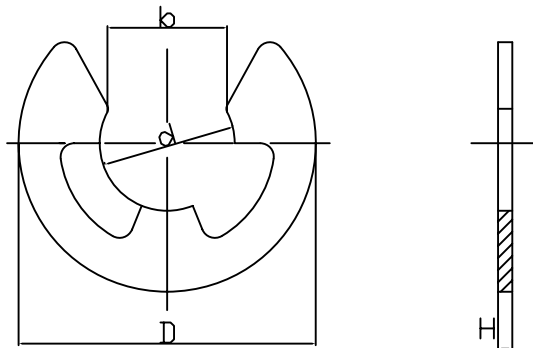

NOT TO SCALE

Material	Spec.		Remark
彈簧鋼 K7	D	6.00 +/-0.20	
Hardness Hardness: HRC 44~52	H	0.40 +/-0.03	
Breaking Torque N/A	d	2.50 +0/-0.09	
	b	2.10 +0/-0.25	
Finish NICKEL			
Salt Spray Test N/A			
Customer 808			
Part No.			
	Recess N/A		

TENSCREW CO., LTD.	DRAWN	CHECKED	APPROVED
	Daphne	Johnson	Johnson