

### Short Ball Lock Single Pin

REVISIONS			
LTR	DESCRIPTION	DATE	APP.
001	SHANK'S END & BALL'S CENTER	FEB./18/2008	JH
002	MOUNTING PLATE & CHANGED SHORT	MAY/23/2013	JH

NOTE :

Name: Prompt Spring Loaded Ball Plunger  
 Specification : Dia. 6.50 x L. 9.00 MM  
 Shank M'tls : AISI 303 Stainless Steel  
 Ball, Spring for Materials :  
 AISI 304 Stainless Steel  
 Finish : Cleaning + Resistance Rust  
 Tensile Strength : 583 kgf ( Max.)  
 ( According to the scale's function of  
 max. valued between shank's diameter  
 & material 60% for tensile strength )  
 Plate Thickness = 0.80 MM (SECC/SGCC)  
 ( Also Being Suitable To T = 1.00 MM )  
 Suggestion Hole Dia. = 5.50 / 5.60 MM  
 Being accompanied by European RoHS  
 Latest Standard in 2013 Year !

- Ditto - But Part Steel As Follows :  
 Shank M'tls : SAE1215MS Cutting Steel  
 Finish : Zincplated Cr3+, 5um.

Tengscrew Co., Ltd. 鄧記有限公司		Client's Confirmed Order	
PART NO. BLP-3DN7180A		Approval No.	Part No.
NAME	PROMPT SPRING LOADED BALL PLUNGER	APPROVED	Johnson
TOL. ±	1 PLC 2 PLC ANGLE	UNIT	mm
MATERIAL	SEE NOTE	SCALE	4:1
FINISH	Cleaning & Resistance Rust	DATE	23-MAY-2013
THE 3RD PROJECTION		DWG. NO.	BLP-3DN7180A
		REV.	0A
			1/1

PROPRIETARY NOTE: THIS SHEET OF ENGINEERING DRAWINGS AND SPECIFICATIONS CONTAINS CONFIDENTIAL, TRADE SECRET, AND OTHER PROPRIETARY INFORMATION OF TENGSCREW CO., LTD. THIS DOCUMENT MAY NOT BE TRANSFERRED OR COPIED WITHOUT THE EXPRESS WRITTEN AUTHORIZATION OF TENGSCREW. IN ADDITIONAL, NEITHER THIS SHEET NOR THE INFORMATION IT CONTAINS MAY BE USED BY OR DISCLOSED TO ANY THIRD PARTY WITHOUT TENGSCREW'S EXPRESS WRITTEN CONSENT.

# Ball Lock Single Pin

REVISIONS			
LTR	DESCRIPTION	DATE	APP.
001	SHANK'S END & BALL'S CENTER	FEB./18/2008	JH

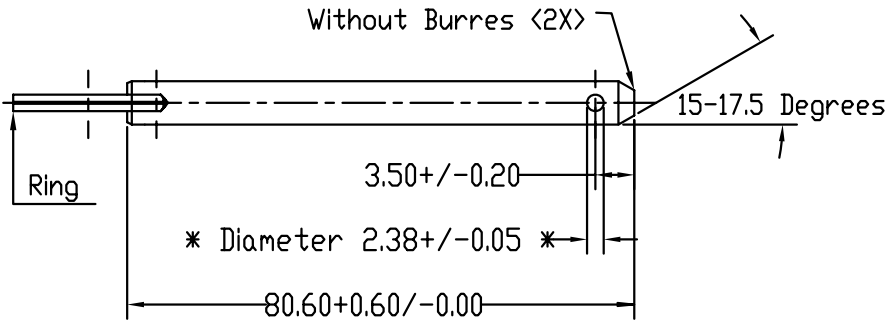

NOTE :

Name: Prompt Spring Loaded Ball Plunger  
 Specification : Dia. 4.76 x L. 80.60 MM  
 Shank M'tls : AISI 303 Stainless Steel  
 Ball, Spring And Ring for Materials :  
 AISI 304 Stainless Steel  
 Finish : Passivated + Resistance Rust  
 Tensile Strength : 583 kgf ( Max.)  
 ( According to the scale's function of  
 max. valued between shank's diameter  
 & material 60% for tensile strength )  
 Being accompanied by European RoHS  
 Latest Standard in 2008.

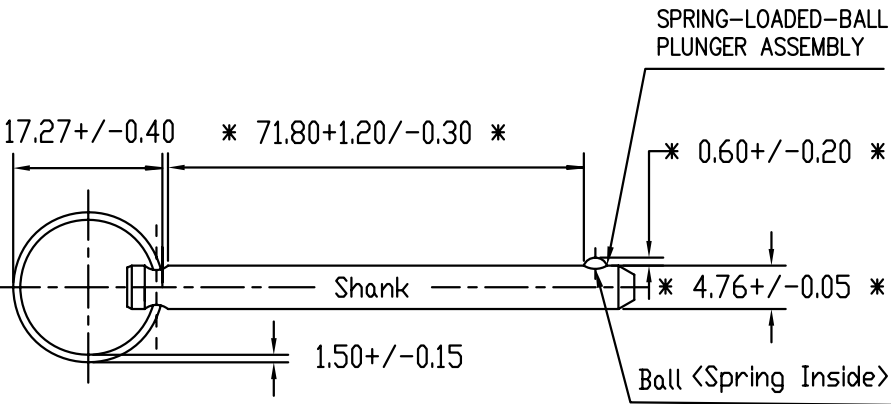

- Ditto - But Part Steel As Follows :

Shank M'tls : AISI 12L14 Cutting Steel  
 Ring M'tls : SWB 60 Spring Steel.  
 Finish : Zincoated Cr3+, 5um.

Tengscrew Co., Ltd.		Customer's Name	
PART NO. BLP-3DN7180		Approval No.	Part No.
NAME	PROMPT SPING LOADED BALL PLUNGER	APPROVED	Johnson
TOL. ±	1 PLC 2 PLC ANGLE	UNIT	mm
MATERIAL	SEE NOTE	SCALE	4:1
FINISH	Passivated & Resistance Rust	DATE	18-FEB-08
THE 3RD PROJECTION	DWG. NO.	REV.	OC

PROPRIETARY NOTE: THIS SHEET OF ENGINEERING DRAWINGS AND SPECIFICATIONS OF TENGSCREW CO., LTD. THIS DOCUMENT MAY NOT BE TRANSFERRED OR COPIED WITHOUT THE EXPRESS WRITTEN AUTHORIZATION OF TENGSCREW. IN ADDITIONAL, NEITHER THIS SHEET NOR THE INFORMATION IT CONTAINS MAY BE USED BY OR DISCLOSED TO ANY THIRD PARTY WITHOUT TENGSCREW'S EXPRESS WRITTEN CONSENT.