

Inquiry No. / Order No.

Drawing No. **TS-0088D**

Rev **A**

**CHIPBOARD SCREWS WITH DRILLING - POINT - MATERIALS = a) INOX 1.4006 (AISI 410), PASSIVATED
b) SAE 10B21 STEEL, CASE HARDENED, ZINC / YELLOW-ZINC PLATED CR3+ BY 8U THICKNESS, HYDROGEN -
EMBRITTEMENT, DOUBLE-FLAT-HEAD WITH 4 RIBS, 6 LOBES (TORX), NEUTRAL-BROWN-200PCS-BOX-PACKED.**

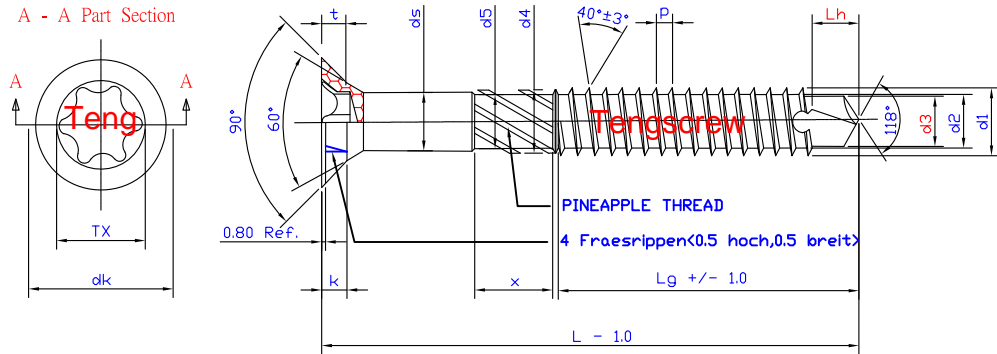

TENGSCREW CO., LTD.
鄧記有限公司

NO. 106, MA - SU ROAD, WAN - LI DISTRICT, NEW-TAIPEI-CITY 207, TAIWAN, REPUBLIC OF CHINA

TELEPHONE : 8862 - 2492 - 7747
FACSIMILE : 8862 - 2492 - 2696
P. O. BOX : 58 WAN-LI 20745
NEW-TAIPEI-CITY, TAIWAN, ROC

SKYPE : Johnson 5523

LINE : ID Code 5010040000

E - MAIL : tengscrew@ms34.hinet.net
WEBSITE : www.tengscrew.com

Normal Diameter		3.0	3.5	4.0	4.5	5.0	6.0
d1	max. / min.		3.6+/-0.1	4.1+/-0.1	4.6+/-0.1	5.1+/-0.1	6.1+/-0.1
d2	max. / min.		2.15+/-0.1	2.5+/-0.1	2.7+/-0.1	3.1+/-0.1	3.7+/-0.1
d3	max. / min.		2.1 - 0.2	2.4 - 0.2	2.6 - 0.2	3.0 - 0.2	3.5 - 0.2
d4	max. / min.		2.9+/-0.1	3.5+/-0.1	3.9+/-0.1	4.0+/-0.1	4.6+/-0.1
d5	max. / min.		2.2+/-0.1	2.6+/-0.1	2.8+/-0.1	3.4+/-0.1	3.7+/-0.1
ds	max. / min.		2.4+/-0.1	2.8+0.2/-0.1	3.0+0.3/-0.2	3.7+/-0.1	4.0+0.3/-0.2
dk	max. / min.		6.7+/-0.2	7.7+/-0.2	8.7+/-0.2	9.7+/-0.2	11.7+/-0.2
k	max. / min.		1.75 + 0.3	2.0 + 0.5	2.2 + 0.5	2.5 + 0.5	3.0 + 0.5
x	max. / min.		4.0+/-0.5	5.0+/-0.5	7.0+/-0.5	8.0+/-0.5	10.0+/-0.5
p	+/-10 %		1.6	1.8	2.0	2.2	2.6
Lh	max. / min.		3.5+0.5/-0.2	4.0+0.5/-0.2	4.5+0.5/-0.2	5.0+0.5/-0.2	5.0+0.5/-0.2
6 Lobes(Torx)	TX		T10	T15	T20	T25	T25
	t max. / min.		1.7 - 0.6	2.2 - 0.4	2.2 - 0.3	2.4 - 0.4	2.8 - 0.4
L - 1.0	Lg+/-1.0	L - 1.0	Lg+/-1.0	L - 1.0	Lg+/-1.0		
25	18	60	36	120	60		
30	21	70	42	130	70		
35	24	80	48	140	70		
40	26	90	54	150	70		
45	28	100	60	160	70		
50	30	110	60				

Materials = a) EN 10088 STEEL CODE 1.4006 (= AISI 410 STAINLESS STEEL)

b) SAE 10B21 MIDDLE CARBON STEEL (= GRADE 8.8)

Breaking Torque	min./Nm		2.5	3.5	4.5	6.5	10
Screw-In Torque	ave./Nm		1.5	2.0	2.5	3.3	6.3
Bending Angle	min.		15	15	15	15	15

TENGSCREW CO., LTD.
鄧記有限公司

Approved by
Johnson
JULY/20/2015

Checked by
Tommy
JULY/20/2015

Drawn by
Tommy
JULY/20/2015

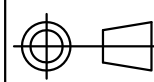

單位 Unit
mm

文件名稱 Document
成品檢驗標準書
(Inspection Certificate)



Inquiry No. / Order No.

Drawing No. **TS-0088E**

Rev **A**

CHIPBOARD SCREWS WITH HOLE - SAE 1022 CARBON STEEL
 FLAT HEAD, POZIDRIVE, CASE-HARDENED, ZINC PLATED CR3+
 CAP COVER ARE AVAILABLE, NEUTRAL BROWN BOX PACKED.

TENGSCREW CO., LTD.
鄧記有限公司

NO. 106, MA - SU ROAD, WAN - LI
 DISTRICT, NEW-TAIPEI-CITY 207,
 TAIWAN, REPUBLIC OF CHINA

TELEPHONE : 8862 - 2492 - 7747
 FACSIMILE : 8862 - 2492 - 2696
 P. O. BOX : 58 WAN-LI 20745
 NEW-TAIPEI-CITY, TAIWAN, ROC

SKYPE : Johnson 5523
 LINE : ID Code 5010040000

E - MAIL : tenscrew@ms34.hinet.net
 WEBSITE : www.tengscrew.com

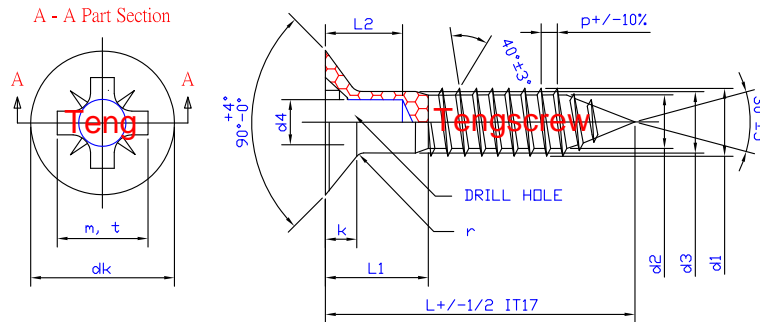

Normal Diameter		Location	4.50	
d1	min. / max.	Major Diameter	4.25	4.50
d2	min. / max.	Minor Diameter	2.45	2.70
d3	min. / max.	Neck Diameter	3.90	4.00
d4	min. / max.	Hole Diameter	2.40	2.45
dk	min. / max.	Head Diameter	8.60	9.00
k	min. / max.	Head Height	2.60	2.80
p	min. / max.	Pitch	1.90	2.10
r	min. / max.	Radian Under The Head	1.80	2.30
L1	min. / max.	Head & Shank Length	10.00	11.00
L2	min. / max.	Hole Depth	7.00	8.00
Pozi Drive	Recess No.	Size	2	2
	m =	Pozidrive Width	4.75	4.85
	t min. / max.	Depth Of Penetration	2.60	3.10

L	min.	max.	L	min.	max.	Length	min.	max.
20	19.10	20	45	43.75	45	10 - 18	- 0.90	0
25	23.95	25	50	48.75	50	18 - 30	- 1.05	0
30	28.95	30	60	58.50	60	30 - 50	- 1.25	0
35	33.75	35	70	68.50	70	50 - 80	- 1.50	0
40	38.75	40	80	78.50	80	80 - 120	- 1.75	0

Mat'l's & Case Hard / Surface Hardness		C-1022 Steel & Case Depth = 0.1 mm <Min.> / 450 - 750 HV 0.3						
Breaking Torque	min./Nm	1.5	2.0	3.0	4.3	6.2	10.8	
Screw-In Torque	ave./Nm	1.0	1.5	2.0	2.5	3.3	6.3	
Bending Angle	min.	15	15	15	15	15	15	

TENGSCREW CO., LTD.
鄧記有限公司

Approved by
 Johnson
 JULY/20/2015

Checked by
Tommy
 JULY/20/2015

Drawn by
Tommy
 JULY/20/2015

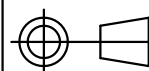

單位 Unit
 mm

文件名稱 Document
 成品檢驗標準書
 (Inspection Certificate)



Inquiry No. / Order No.

Drawing No. **TS-0088A**

Rev **A**

**CHIPBOARD SCREWS - SAE 1022 CARBON STEEL
DOUBLE-FLAT-HEAD, POZIDRIVE, CASE-HARDENED, ZINC OR
YELLOW-ZINC-PLATED CR3+, NEUTRAL BROWN BOX PACKED.**

**TENGSCREW CO., LTD.
鄧記有限公司**

NO. 106, MA - SU ROAD, WAN - LI
DISTRICT, NEW-TAIPEI-CITY 207,
TAIWAN, REPUBLIC OF CHINA
TELEPHONE : 8862 - 2492 - 7747
FACSIMILE : 8862 - 2492 - 2696
P. O. BOX : 58 WAN-LI 20745
NEW-TAIPEI-CITY, TAIWAN, ROC
SKYPE : Johnson 5523
LINE : ID Code 5010040000
E - MAIL : tenscrew@ms34.hinet.net
WEBSITE : www.tengscrew.com

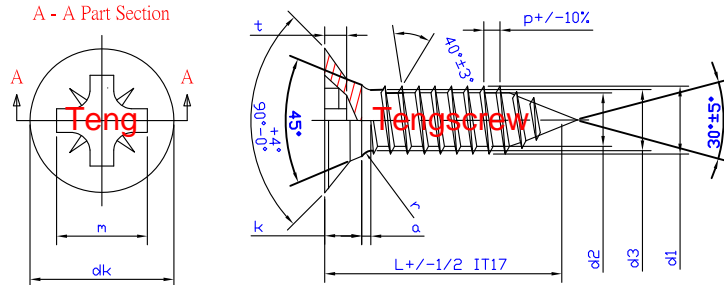

Normal Diameter		3.0	3.5	4.0	4.5	5.0	6.0	
d1	min.	2.6	3.3	3.75	4.25	4.7	5.7	
	max.	3.0	3.5	4.0	4.5	5.0	6.0	
d2	min.	1.7	2.0	2.25	2.45	2.7	3.4	
	max.	1.9	2.2	2.5	2.7	3.0	3.7	
d3	min.	2.05	2.35	2.75	3.10	3.45	4.20	
	max.	2.25	2.55	2.95	3.30	3.65	4.40	
dk	min.	5.6	6.6	7.5	8.5	9.5	11.5	
	max.	6.0	7.0	8.0	9.0	10.0	12.0	
k	max.	1.9	2.1	2.5	2.7	3.0	3.6	
p	+/-10 %	1.35	1.6	1.8	2.0	2.2	2.6	
a	max.	1.6	1.8	2.0	2.2	2.5	3.0	
r	min.	1.2	1.5	1.6	1.8	2.0	2.0	
	max.	1.6	1.9	2.1	2.3	2.6	2.6	
Pozi Drive	Recess No.		1	2	2	2	3	
	m =		3.0	4.0	4.4	4.8	5.3	6.6
	t	min.	1.6	1.6	2.05	2.6	3.0	3.0
max.		2.0	2.1	2.5	3.1	3.45	3.45	
L	min.		L	min.	max.	L	min.	max.
10	9.25	10	35	33.75	35	80	78.50	80
12	11.10	12	40	38.75	40	90	88.25	90
16	15.10	16	45	43.75	45	100	98.25	100
20	18.95	20	50	48.75	50	120	118.25	120
25	23.95	25	60	58.50	60	130	128.00	130
30	28.95	30	70	68.50	70	140	138.00	140

Mat'l's & Case Hard / Surface Hardness		C-1022 Steel & Case Depth = 0.1 mm <Min.> / 450 - 750 HV 0.3					
Breaking Torque	min./Nm	1.5	2.0	3.0	4.3	6.2	10.8
Screw-In Torque	ave./Nm	1.0	1.5	2.0	2.5	3.3	6.3
Bending Angle	min.	15	15	15	15	15	15

**TENGSCREW CO., LTD.
鄧記有限公司**

Approved by
Johnson
JULY/20/2015

Checked by
Tommy
JULY/20/2015

Drawn by
Tommy
JULY/20/2015

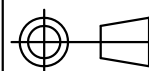

單位 Unit
mm

文件名稱 Document
成品檢驗標準書
(Inspection Certificate)

Inquiry No. / Order No.

Drawing No. **TS-0088B**

Rev **A**

CHIPBOARD SCREWS - SAE 1022 CARBON STEEL
DOUBLE-PAN-HEAD, POZIDRIVE, CASE-HARDENED, ZINC OR
YELLOW-ZINC-PLATED CR3+, NEUTRAL BROWN BOX PACKED.

TENGSCREW CO., LTD.

鄧記有限公司

NO. 106, MA - SU ROAD, WAN - LI
 DISTRICT, NEW-TAIPEI-CITY 207,
 TAIWAN, REPUBLIC OF CHINA

TELEPHONE : 8862 - 2492 - 7747

FACSIMILE : 8862 - 2492 - 2696

P. O. BOX : 58 WAN-LI 20745

NEW-TAIPEI-CITY, TAIWAN, ROC

SKYPE : Johnson 5523

LINE : ID Code 5010040000

E - MAIL : tenscrew@ms34.hinet.net

WEBSITE : www.tenscrew.com

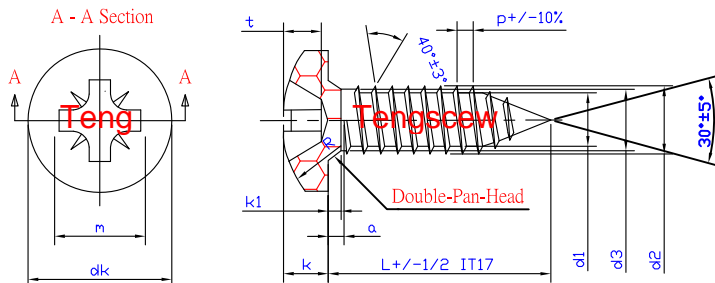

Normal Diameter		3.0	3.5	4.0	4.5	5.0	6.0	
d1	min.	2.80	3.30	3.75	4.25	4.70	5.70	
	max.	3.00	3.50	4.00	4.50	5.00	6.00	
d2	min.	1.65	1.90	2.25	2.45	2.75	3.30	
	max.	1.90	2.15	2.50	2.70	3.00	3.60	
d3	min.	2.05	2.35	2.75	3.10	3.45	4.20	
	max.	2.25	2.55	2.95	3.30	3.65	4.40	
dk	min.	5.5	6.4	7.4	8.4	9.4	11.3	
	max.	6.0	7.0	8.0	9.0	10.0	12.0	
k	min.	2.1	2.2	2.7	2.9	3.3	4.0	
	max.	2.4	2.5	3.0	3.2	3.6	4.3	
p	+/-10 %	1.35	1.6	1.8	2.0	2.2	2.6	
a	max.	2.0	2.5	2.8	3.2	3.6	4.0	
k1	ave.	0.7	0.9	1.0	1.2	1.3	1.5	
R	ave.	6	7	8.5	9	10	11	
Pozid Drive	Recess No.		1	2	2	2	3	
	m =		3.0	4.0	4.2	4.4	5.0	6.3
	t	min.	1.76	1.60	1.85	2.05	2.64	2.72
max.		2.01	2.06	2.31	2.51	3.10	3.18	
L	min.							
	max.							
12	11.10	12	40	38.75	40	90	88.25	90
16	15.10	16	45	43.75	45	100	98.25	100
20	18.95	20	50	48.75	50	110	108.25	110
25	23.95	25	60	58.50	60	120	118.25	120
30	28.95	30	70	68.50	70	130	128.00	130
35	33.75	35	80	78.50	80	140	138.00	140

Matl's & Case Hard / Surface Hardness C-1022 Steel & Case Depth = 0.1 mm <Min.> / 450 - 750 HV 0.3

Breaking Torque min./Nm 1.5 2.0 3.0 4.3 6.2 10.8

Screw-In Torque ave./Nm 1.0 1.5 2.0 2.5 3.3 6.3

Bending Angle min. 15 15 15 15 15 15

TENGSCREW CO., LTD.
鄧記有限公司

Approved by
 Johnson
 JULY/20/2015

Checked by
 Tommy
 JULY/20/2015

Drawn by
 Tommy
 JULY/20/2015

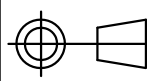

單位 Unit
 mm

文件名稱 Document
 成品檢驗標準書
 (Inspection Certificate)



Inquiry No. / Order No.

Drawing No. **TS-0088C**

Rev **A**

CHIPBOARD SCREWS - AISI 410/304 STAINLESS STEEL
DOUBLE-FLAT-HEAD, 6 LOBES (TORX), BRIGHT-HARDENED,
PASSIVATED < CLEANING >, NEUTRAL BROWN BOX PACKED.

TENGSCREW CO., LTD.
鄧記有限公司

NO. 106, MA - SU ROAD, WAN - LI
 DISTRICT, NEW-TAIPEI-CITY 207,
 TAIWAN, REPUBLIC OF CHINA
 TELEPHONE : 8862 - 2492 - 7747
 FACSIMILE : 8862 - 2492 - 2696
 P. O. BOX : 58 WAN-LI 20745
 NEW-TAIPEI-CITY, TAIWAN, ROC
 SKYPE : Johnson 5523
 LINE : ID Code 5010040000
 E - MAIL : tenscrew@ms34.hinet.net
 WEBSITE : www.tengscrew.com

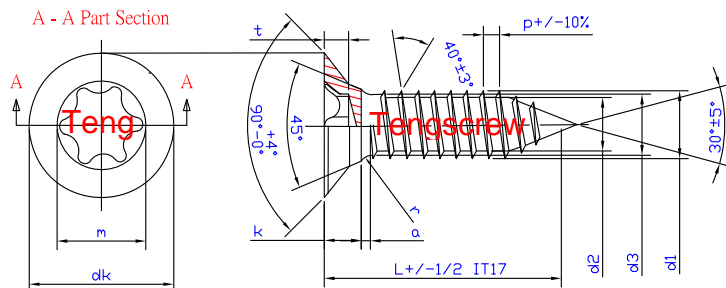

Normal Diameter		3.0	3.5	4.0	4.5	5.0	6.0	
d1	min.	2.6	3.3	3.75	4.25	4.7	5.7	
	max.	3.0	3.5	4.0	4.5	5.0	6.0	
d2	min.	1.7	2.0	2.25	2.45	2.7	3.4	
	max.	1.9	2.2	2.5	2.7	3.0	3.7	
d3	min.	2.05	2.35	2.75	3.10	3.45	4.20	
	max.	2.25	2.55	2.95	3.30	3.65	4.40	
dk	min.	5.6	6.6	7.5	8.5	9.5	11.5	
	max.	6.0	7.0	8.0	9.0	10.0	12.0	
k	max.	1.9	2.1	2.5	2.7	3.0	3.6	
p	+/-10 %	1.35	1.6	1.8	2.0	2.2	2.6	
a	max.	1.6	1.8	2.0	2.2	2.5	3.0	
r	min.	1.2	1.5	1.6	1.8	2.0	2.0	
	max.	1.6	1.9	2.1	2.3	2.6	2.6	
6 Lobes(Torx)	Recess No.		T10	T10/T15	T15	T20/T25	T25	T25
	m =		2,82	3,35	3,35	4,53	4,53	4,53
	t	min.	1.35	1.50	1.60	1.90	2.25	3.00
max.		1.50	1.65	1.75	2.10	2.50	3.25	
L	min.							
	max.							
10	9.25	10	35	33.75	35	80	78.50	80
12	11.10	12	40	38.75	40	90	88.25	90
16	15.10	16	45	43.75	45	100	98.25	100
20	18.95	20	50	48.75	50	120	118.25	120
25	23.95	25	60	58.50	60	130	128.00	130
30	28.95	30	70	68.50	70	140	138.00	140

Mat's = AISI 410 / 304 / SAE 1022

AISI 410 S.S. / AISI 304 S.S. (SAE 1022 STEEL ARE AVAILABLE)

Breaking Torque min./Nm 1.5 2.0 3.0 4.3 6.2 10.8

Screw-In Torque ave./Nm 1.0 1.5 2.0 2.5 3.3 6.3

Bending Angle min. 15 15 15 15 15 15

TENGSCREW CO., LTD.
鄧記有限公司

Approved by
 Johnson
 JULY/20/2015

Checked by
Tommy
 JULY/20/2015

Drawn by
Tommy
 JULY/20/2015

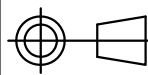

單位 Unit
 mm

文件名稱 Document
 成品檢驗標準書
 (Inspection Certificate)

